



# NSF Grant – Network Performance Testing

Adam Wellner  
Christos Belegrios  
Grant Sharpe

Integrated Information  
Technology Department  
ITEC 564 -  
IT Capstone Projects  
Fall 2018

## Project Description

This project compares the throughput performance of four different TCP congestion control protocols: Reno, HTCP, BBR, and Cubic. The project studies the impact of maximum segment size and parallel streams on big flows, in the presence of packet losses and latency. Results will provide novel findings related to moving big data across a 40 Gbps network.

## Project Mission Statement

This project will compare throughput performance of different TCP congestion-control algorithms on a 40 Gbps network, under packet losses and latency. Iperf tests will provide throughput results on HTCP, Cubic, Reno, and BBR to be compared and evaluated, thus drawing conclusions.

## Lessons Learned

*"It's critical to spend your time generating a set of basic, main goals so that the project timeline stays organized."*

– Christos Belegrios

*"Always leave room for potential mishaps, it can save you in the long run."*

– Adam Wellner

*"Don't forget to have fun!"*

– Grant Sherman

## Specific Client Needs

- Access to a high-speed 100 Gbps network
- Access to specialized compute devices capable of transmit/receive data at 40 Gbps
- Remote connectivity to conduct testing
- Clearly written findings and procedures
- Timely results

## Project Success Factors

- Ability to perform testing accurately
- Successful network emulation
- Sufficient amount of data to create comparisons of test configurations conducted
- Able to draw conclusion from documented results and comparisons

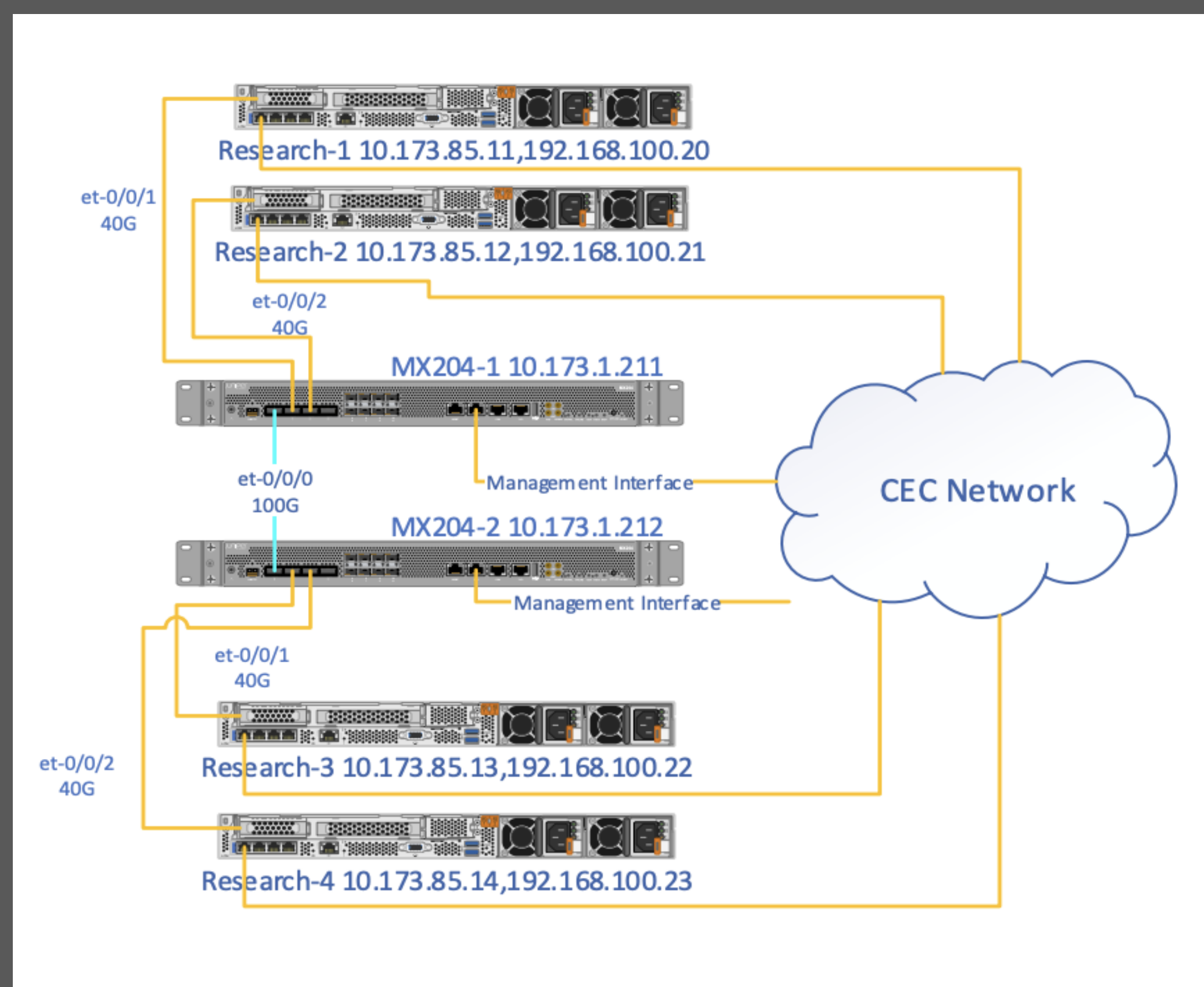

## Product Development & Deliverables

- **Cyberinfrastructure required for tests**
  - 100 Gbps network
  - Specialized end devices, referred to as Data Transfer Nodes (DTNs)
  - Software emulator running on DTNs to vary corruption rate, latency, maximum segment size, and number of parallel streams
- **Tests**
  - Performance results (throughput) of the four TCP congestion control algorithms:
    - Reno
    - Cubic
    - HTCP
    - BBR
  - Control variables for testing include:
    - Corruption rate
    - Number of parallel streams
    - Maximum segment size
- **Final Report – Report summarizing findings**

## Project Budget

- **Anticipated (Time) Budget:** 33 hours per team member
- **Actual Project (Time) Budget:** 123.5 hours total (roughly 41 hours per team member)

## Chart & Deliverable

10ms Delay 0.001% Corruption 1 Stream

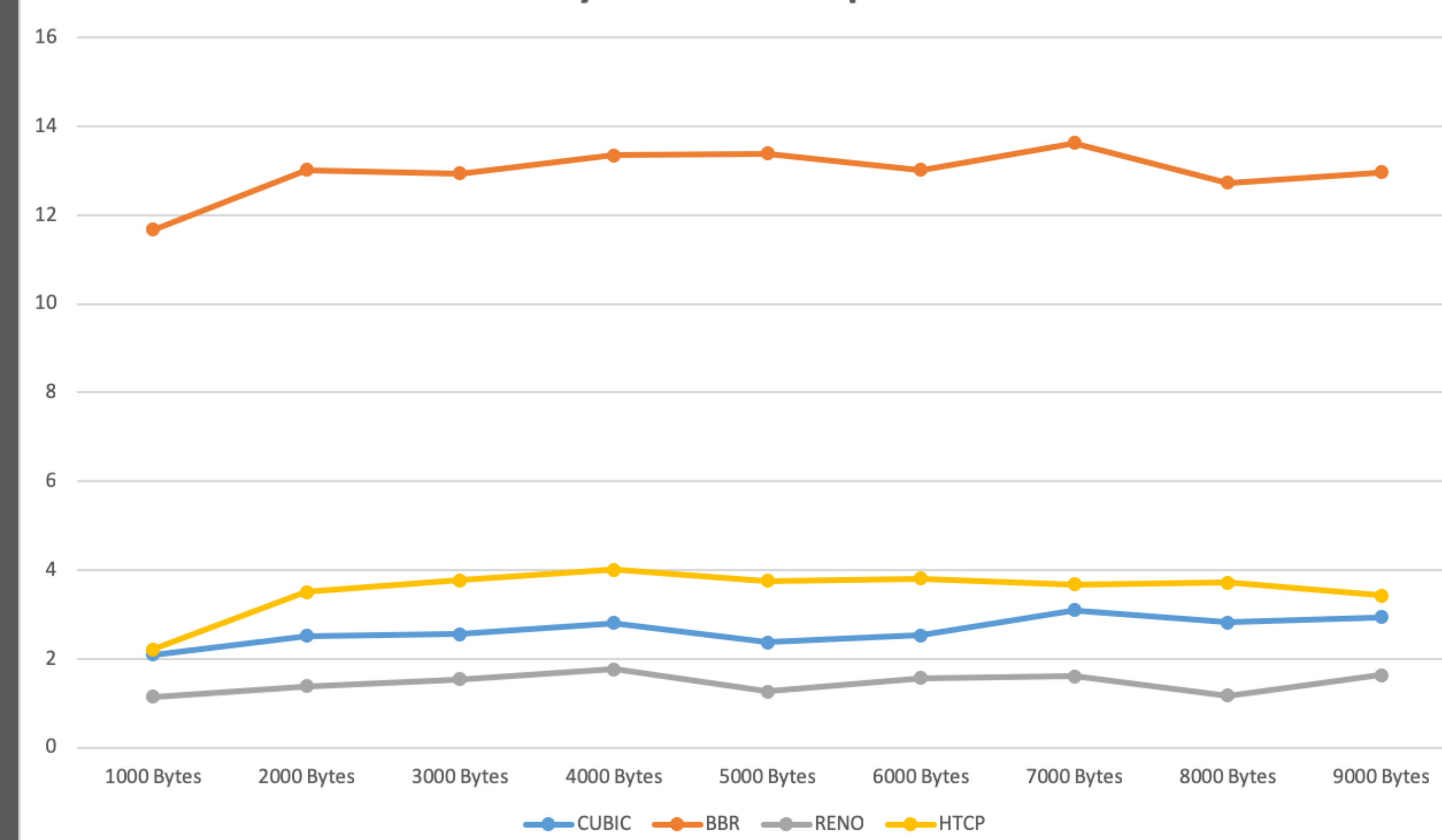

## Technologies Used

- **Unix command line** for interacting with server operating systems
- **Juniper switches** implemented within University of South Carolina network infrastructure
- **Netem** – Allows network emulation across different devices
- **iPerf** – Used to monitor, conduct, and tune network performance
- Other standards involved with the project include:
  - TCP
  - Python
  - Congestion control algorithms.

## Project Results and Future Recommendations

**Project Results** – A large number of tests were conducted on the four available servers with multiple configurations implemented to generate valuable data that can be interpreted, potentially improving the testing conditions and future configurations of the testing environment.

**Future Recommendations** – The project should proceed by conducting additional tests with the four available servers, and generating and recording valuable data that can be compared to other data sets of similar origin.

## PMBOK Project Processes Used

During this project, we developed a project charter, planned our resources and what was needed to conduct the tests, and managed communications and prolonged stakeholder engagement by meeting frequently with the stakeholder.

## Key Stakeholders

- Jorge Crichigno, Ph.D.  
jcrichigno@cec.sc.edu
- University of South Carolina

## MS Project Gantt Chart of Major Project Milestones (Key Deliverables)

